

PLAN VIEW



FRONT ELEVATION



LEFT 3D VIEW



RIGHT 3D VIEW

Prepared for:

Width:	4000 mm	Dwarf Wall Ht:	0 mm	Base Area:	13.26 sq.m
Depth:	4000 mm	Frame Ht:	2100 mm	Int Volume:	30.93 cu.m
Ridge Height:	2989 mm	Floor Area:	11.96 sq.m	Ext Volume:	33.81 cu.m

**Fortress Windows**  
**Units 3 and 5 Pickerings House**  
**Netherton Road**  
**Wishaw, North Lanarkshire, ML2 0EQ**

**Tel : 01698 358175 Fax: 01698 356195**

**Fortress Windows**  
 Units 3 and 5 Pickerings House  
 Netherton Road  
 Wishaw, North Lanarkshire, ML2 0EQ  
 Tel : 01698 358175 Fax: 01698 356195

Email : peter.murray32@btinternet.com Web: www.fortresspvcwindows.com

Name:

Address:

Date: **4 / 2 / 2012**

**BASE LAYOUTS**

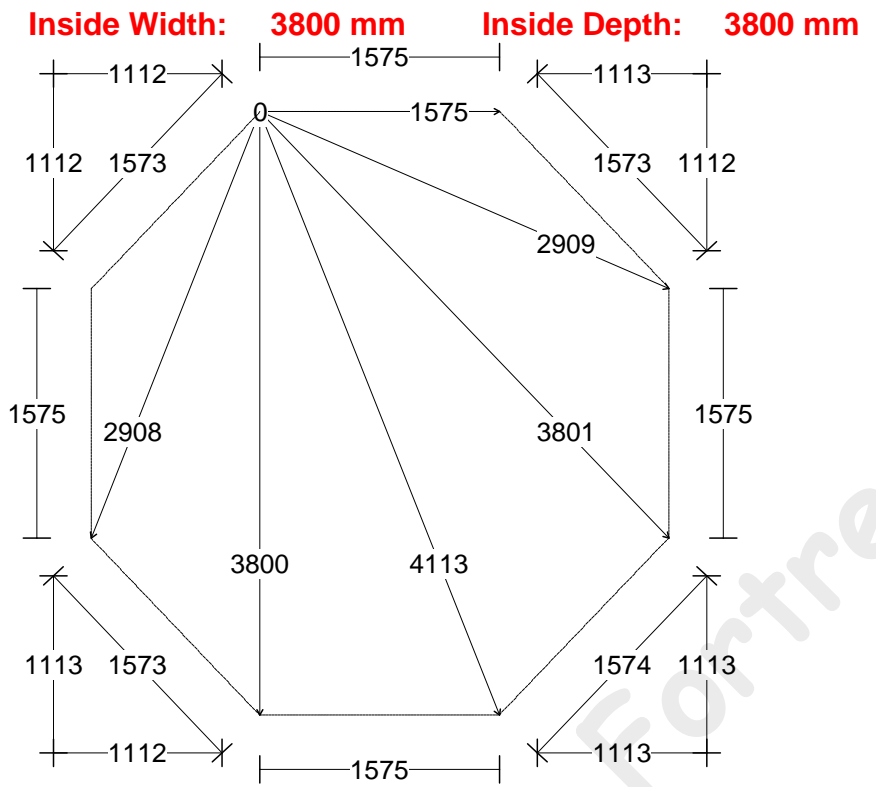

**INTERNAL CILL**

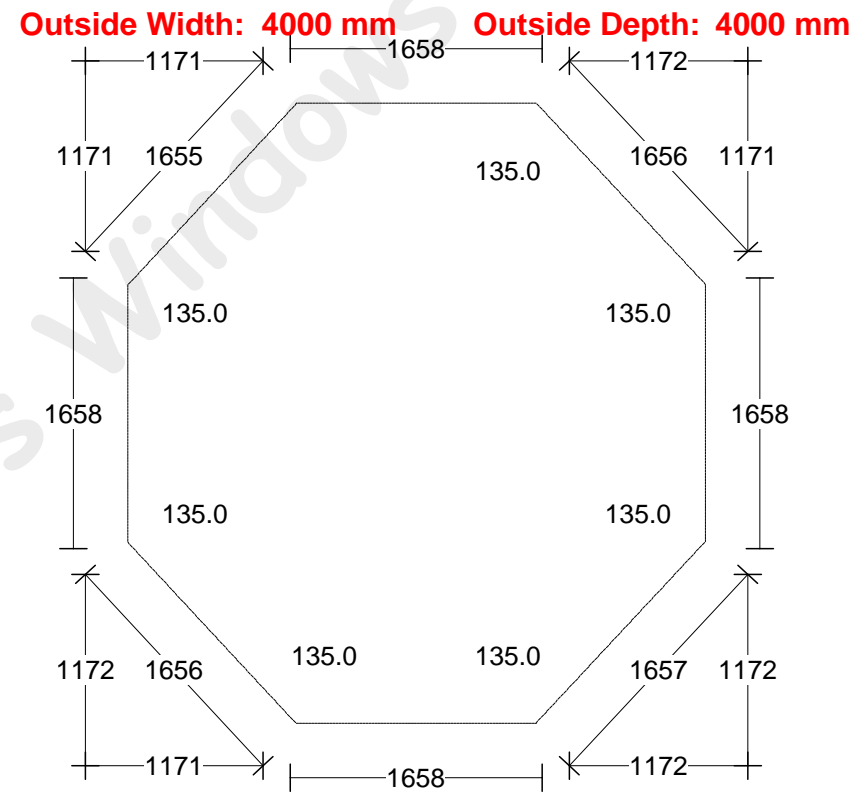

**EXTERNAL BRICKWORK**

**Fortress Windows**

Units 3 and 5 Pickerings House  
Netherton Road

Wishaw, North Lanarkshire, ML2 0EQ

Tel : 01698 358175

Fax : 01698 356195

Name:

Date: 4 / 2 / 2012

Page - 1 / 4

**CONSERVATORY SIDE DETAILS**

1

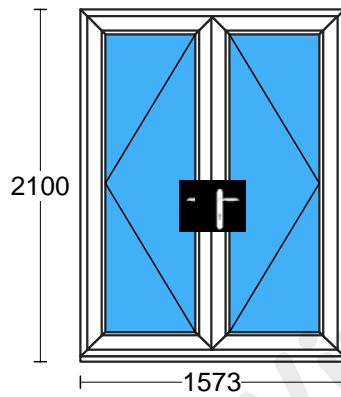

2

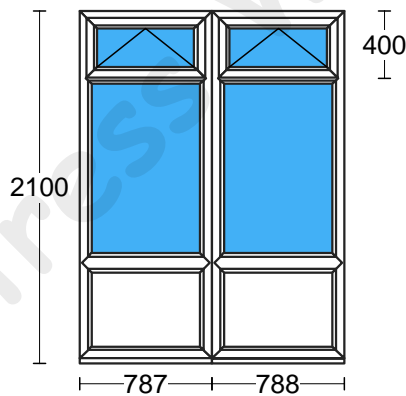

3

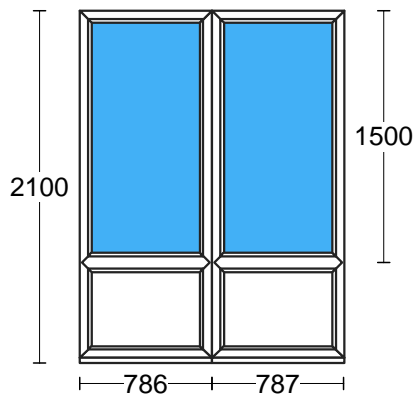

**Fortress Windows**

Units 3 and 5 Pickerings House  
Netherton Road

Wishaw, North Lanarkshire, ML2 0EQ

Tel : 01698 358175

Fax : 01698 356195

Name:

Date: 4 / 2 / 2012

**Page - 2 / 4**

**CONSERVATORY SIDE DETAILS**

**4**

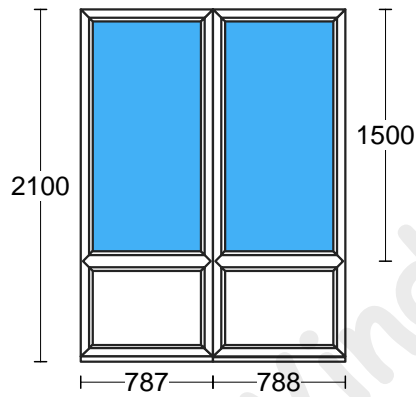

**5**

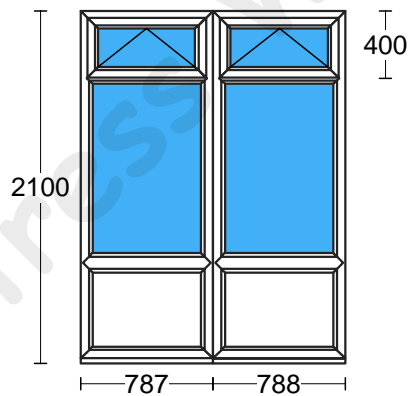

**6**

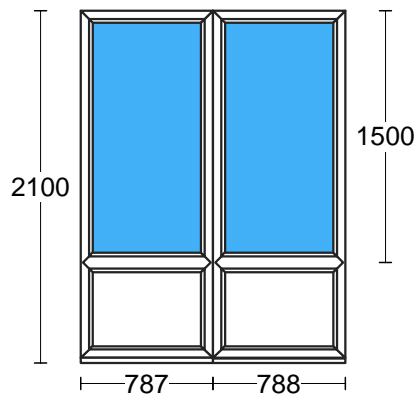

**Fortress Windows**

Units 3 and 5 Pickerings House  
Netherton Road

Wishaw, North Lanarkshire, ML2 0EQ

Tel : 01698 358175

Fax : 01698 356195

Name:

Date: 4 / 2 / 2012

**Page - 3 / 4**

**CONSERVATORY SIDE DETAILS**

7

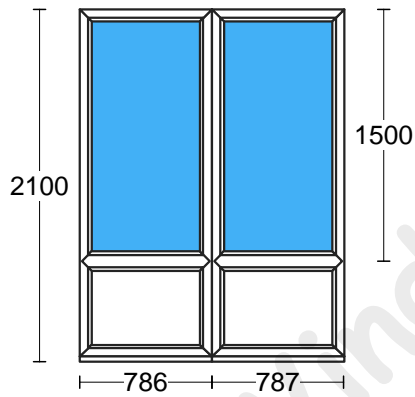

8

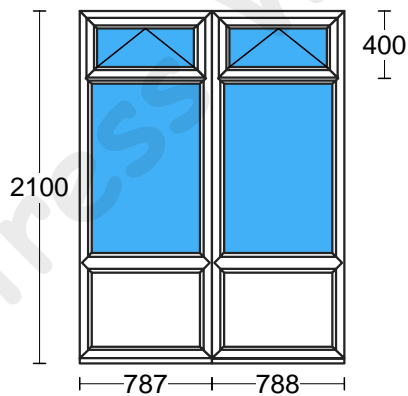

**Fortress Windows**

Units 3 and 5 Pickerings House  
Netherton Road

Wishaw, North Lanarkshire, ML2 0EQ

Tel : 01698 358175

Fax : 01698 356195

Name:

Date: 4 / 2 / 2012

Page - 4 / 4

**CONSERVATORY SIDE DETAILS**

Side Identification

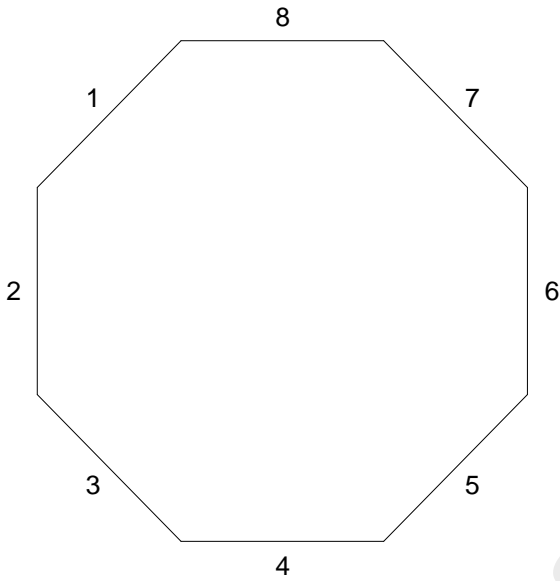

Dwarf Wall Ht = 0 mm

Floor Area = 11.96 m<sup>2</sup>

Frame Height = 2100 mm

Notes:

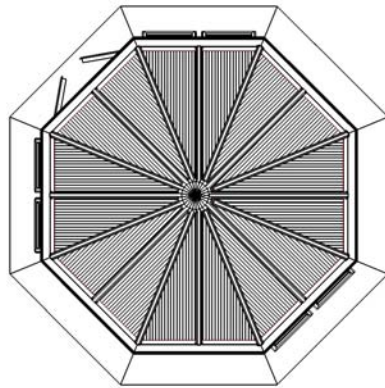

PLAN VIEW Scale 1:100

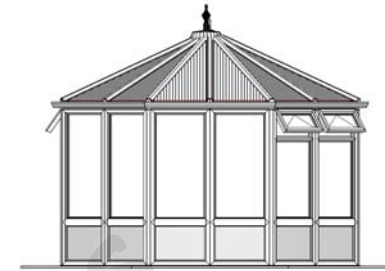

FRONT ELEVATION Scale 1:100

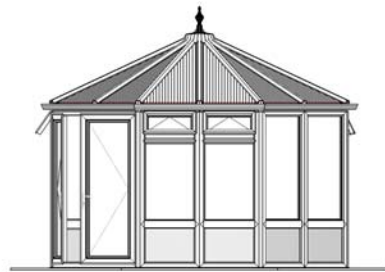

LEFT VIEW Scale 1:100

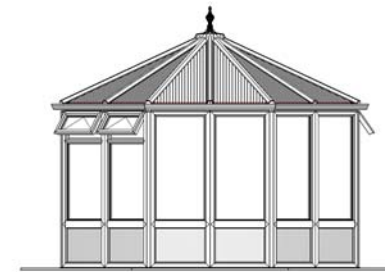

RIGHT VIEW Scale 1:100

Prepared for:



Date: 4 / 2 / 2012

Designers Signature:

O/A Width: 4000 mm O/A Depth: 4000 mm

Gutter Ht: 2100 mm

Roof Pitch: 25.0°

Internal Volume: 30.93 m<sup>3</sup>

Dwarf Wall Ht: 0 mm

Floor Area: 11.96 m<sup>2</sup>

**Fortress Windows**

**Units 3 and 5 Pickerings House**

**Netherton Road**

**Wishaw, North Lanarkshire, ML2 0EQ**

**Tel : 01698 358175 Fax: 01698 356195**